



Rebel collection

THE ITALIAN WAY TO LUXURY



formerin  
italia

Rebel collection

design: Joe Gentile - Fabio Crippa

A very personal aesthetic vision made of timeless lines and volumes, embellished with valuable details that make the company's style immediately recognisable. Thanks to the profound technical maturity and the careful knowledge of the production mechanisms, Former In Italia manages to create completely new solutions by experimenting with the potential and limits of the materials, using high-level technology in each product, in a very elegant and hidden way, without the need to exhibit it.

Una personalissima visione estetica fatta di linee e volumi senza tempo, impreziositi da dettagli di pregio che rendono lo stile dell'azienda immediatamente riconoscibile. Grazie alla profonda maturità tecnica e all'attenta conoscenza dei meccanismi della produzione, Former In Italia riesce a creare soluzioni del tutto inedite sperimentando le potenzialità e i limiti dei materiali, utilizzando una tecnologia di alto livello in ogni prodotto, senza che essa venga tuttavia esibita ma altresì in modo elegantemente nascosto, senza il bisogno di esibirlo.

Between traditional craftsmanship and manufacturing innovation, the Rebel Collection expands with new proposals, complements and refined objects for decoration, completing Former In Italia lifestyle. Designed by Joe Gentile e Fabio Crippa, these products can give life to unique and original environments.

“The spirit that led us to develop the Rebel Collection is to create projects that challenges our skills and increase our know how and expertise”.

Tra tradizione e innovazione, la collezione si amplia con nuove proposte, complementi e raffinati oggetti per il décor che completano il lifestyle Former In Italia.

Disegnate da Joe Gentile e Fabio Crippa, queste collezioni sono in grado di dar vita ad ambienti unici e originali .  
 “Lo spirito che ci ha animato nel costruire la Collezione Rebel è quello che ci ha sempre guidato: sviluppare progetti che ci interessino, che ci sfidino, portando avanti le nostre capacità e competenze”.



Creating constant dialogue between craftsmanship and advanced manufacturing, the pieces in the new collection express the profound meaning of design according to Foremer In Italia in every minute detail.

Versatile products with sophisticated, decisive character that's never conventional, pieces that stand out for their high-quality materials, sartorial techniques, and the brand's near-obsessive research into finishes, shapes, textures and colours.

Un continuo dialogo tra artigianalità e tecnologia produttiva, le proposte della nuova collezione raccontano in ogni più piccolo dettaglio il senso profondo del progettare secondo Foremer In Italia. Prodotti versatili dal carattere elegante e deciso, mai convenzionale, che si contraddistinguono per l'altissima qualità dei materiali, per le lavorazioni sartoriali e per una ricerca maniacale su finiture, forme, texture e colori.

Inspired by high fashion creations: the ongoing quest to find the right balance between uniqueness and tailoring. Clean forms, attention to detail, sophisticated materials. Furniture that shapes a dynamic, welcoming domestic landscape. Elegance, lightness, exceptional comfort, enveloping lines reinterpreted in a contemporary key. Tradition and innovation, in the style of Former In Italia.

Ispirazione, la creazione di alta moda: la costante ricerca dell'equazione tra unicità e taglio sartoriale. Pulizia delle forme, attenzione per il dettaglio, ricerca sui materiali. Arredi che delineano un paesaggio domestico dinamico e accogliente. Eleganza, leggerezza, grande comfort, linee classiche reinterpretate in chiave contemporanea. Tradizione e innovazione, nello stile Former In Italia.





### **Tablò** Dining Table / Tavolo

Tablò confirms the basic idea of the entire collection: a unique metal base made up of painted vertical tubes that are partially leather covered with leather, connected by the precious circular support of the surface. The table top can be made of marble, glass or wood.

Tablò conferma l'idea base dell'intera collezione: una singolare base in metallo composta da tubolari verticali verniciati e rivestiti parzialmente in pelle, raccordati dal prezioso sostegno circolare del piano.

Il top del tavolo può essere realizzato in marmo, vetro o legno.

### **Iris** Little Armchair / Poltroncina

Iris expresses the perfect balance between aesthetics and innovation in a perceptible manner, amidst technology and tradition that inspires the entire collection. It can be customized with several coverings, from fabrics, to velvets to leathers.

Iris esprime in modo percepibile l'equilibrio perfetto tra estetica e innovazione, tra tecnologia e tradizione a cui si ispira tutta la collezione.

La possibilità di rivestirla con diversi materiali, tessuti, velluti, pelle, permette di personalizzarla in maniera unica.





Dining table / Tavolo

Tablò

Through continuous dialogue, bounded by craftsmanship and production technology, the collection recounts the manufacturing capabilities of a historic company in every detail.

In un continuo dialogo tra artigianalità e tecnologia produttiva, la collezione racconta in ogni più piccolo dettaglio le capacità manifatturiere di un'azienda storica.





**Iris** Little Armchair / Poltroncina

The handle, in addition to being the characterising element of the armchair, is a detail of great stylistic elegance.

Il dettaglio della maniglia, oltre ad essere l'elemento caratterizzante della poltroncina, sono un dettaglio di grande eleganza stilistica.

**Tablò** Dining Table / Tavolo

Actual sculptural objects, expertly crafted, the table and chair are characterised by the combination of metal and leather that distinguish the entire collection.

Veri e propri oggetti scultorei, tavolo e sedia sono caratterizzati dall'abbinamento di metallo e pelle, sapientemente lavorati, che caratterizza tutta la collezione.





**Iris** Little Armchair / Poltroncina

Iris manages to interpret the space by defining the style of a very important area of the house. It is available in various finishes as per samples.

Iris riesce a interpretare lo spazio definendo lo stile di una zona di grande tendenza della casa. E' disponibile in diverse finiture come da campionario.



### Baron

#### Bar cabinet / Mobile Bar

Objects of great design that easily blend in with the rest of the furniture, or live their own identity thanks to the combination with different and particular elements. The design of the credenzas and sideboards, in fact, can stand out in a living area even while interacting with other furnishing accessories.

Oggetti di grande design che possono uniformarsi al resto dell'arredo, oppure vivere di propria identità grazie all'abbinamento con elementi differenti e particolari. Il design delle credenze e delle madie, infatti, può spiccare in una zona giorno pur nell'interazione con altri complementi d'arredo.

The presence of a design container in a living space transcends its function of organization and containment. In every area of the house they become a piece of furniture that has its own identity, even in interaction with other furnishing accessories, thanks to the particular design and craftsmanship that expands its aesthetic value. Functional, contemporary products with an atypical and unmistakable style, capable of reconciling the highest cabinet-making tradition with the use of sophisticated production technologies.

La presenza di un contenitore di design in uno spazio abitativo trascende la sua funzione di organizzazione e contenimento. In ogni zona della casa diventano pezzi di arredo che vivono di propria identità, pur nell'interazione con altri complementi d'arredo, grazie al design particolare e alle lavorazioni artigianali che ne ampliano il valore estetico. Prodotti funzionali, contemporanei e dallo stile atipico e inconfondibile, in grado di conciliare la più alta tradizione ebanistica con l'impiego di sofisticate tecnologie produttive.

**Bar cabinet / Mobile Bar****Baron**

A design container can carry out its function of storing, supporting and accommodating the objects of our daily life with great elegance and detail.

Un contenitore di design può assolvere alla sua funzione di riporre, appoggiare e accogliere gli oggetti della nostra vita quotidiana con grande eleganza di dettagli.





**Baron** Bar cabinet / Mobile Bar

The precious finishes, the angular opening of the side doors and the upper entrance created by the slight retraction of the top, are details that combine contemporaneity with the flavour of tradition.

Le finiture preziose, l'apertura angolare delle ante laterali e la gola superiore creata dal lieve arretramento del piano sono dettagli che uniscono la contemporaneità al sapore della tradizione.



**Baron** Bar cabinet / Mobile Bar

Precious details such as the backrest in backlit onyx and the incredibly accurate workmanship make this piece of furniture an object of great prestige.

Dettagli preziosi come lo schienale in onice retrolluminato e le accuratissime lavorazioni fanno di questo mobile un oggetto di grande prestigio.



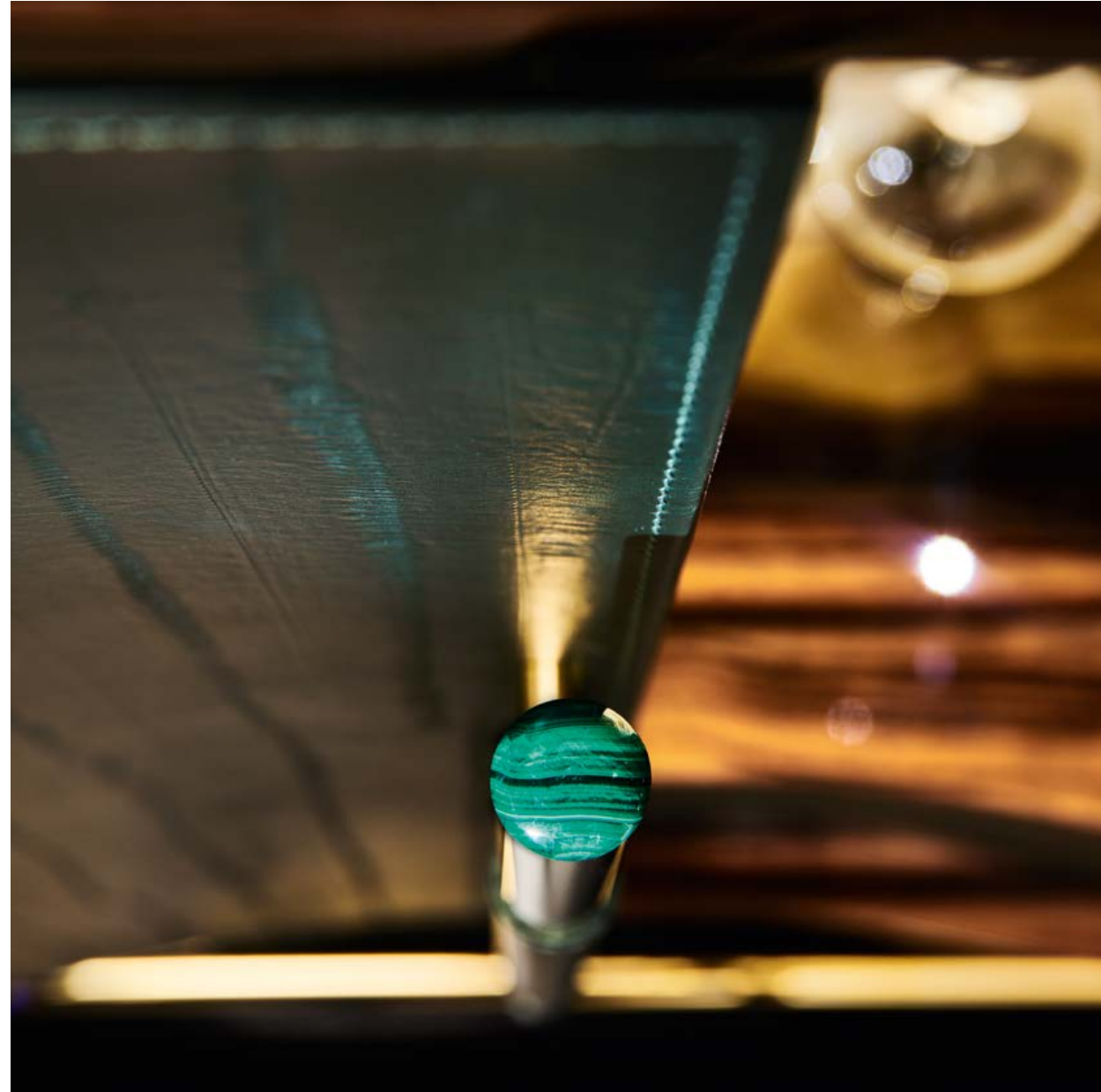

**Baron** Bar cabinet / Mobile Bar

Precious stones embellish and define the cabinet handles. A spacious drawer, also internally lined, holds the most expensive objects.

Pietre preziose abbelliscono e definiscono le maniglie del mobile. Uno spazioso cassetto rivestito anche internamente accoglie gli oggetti più cari.

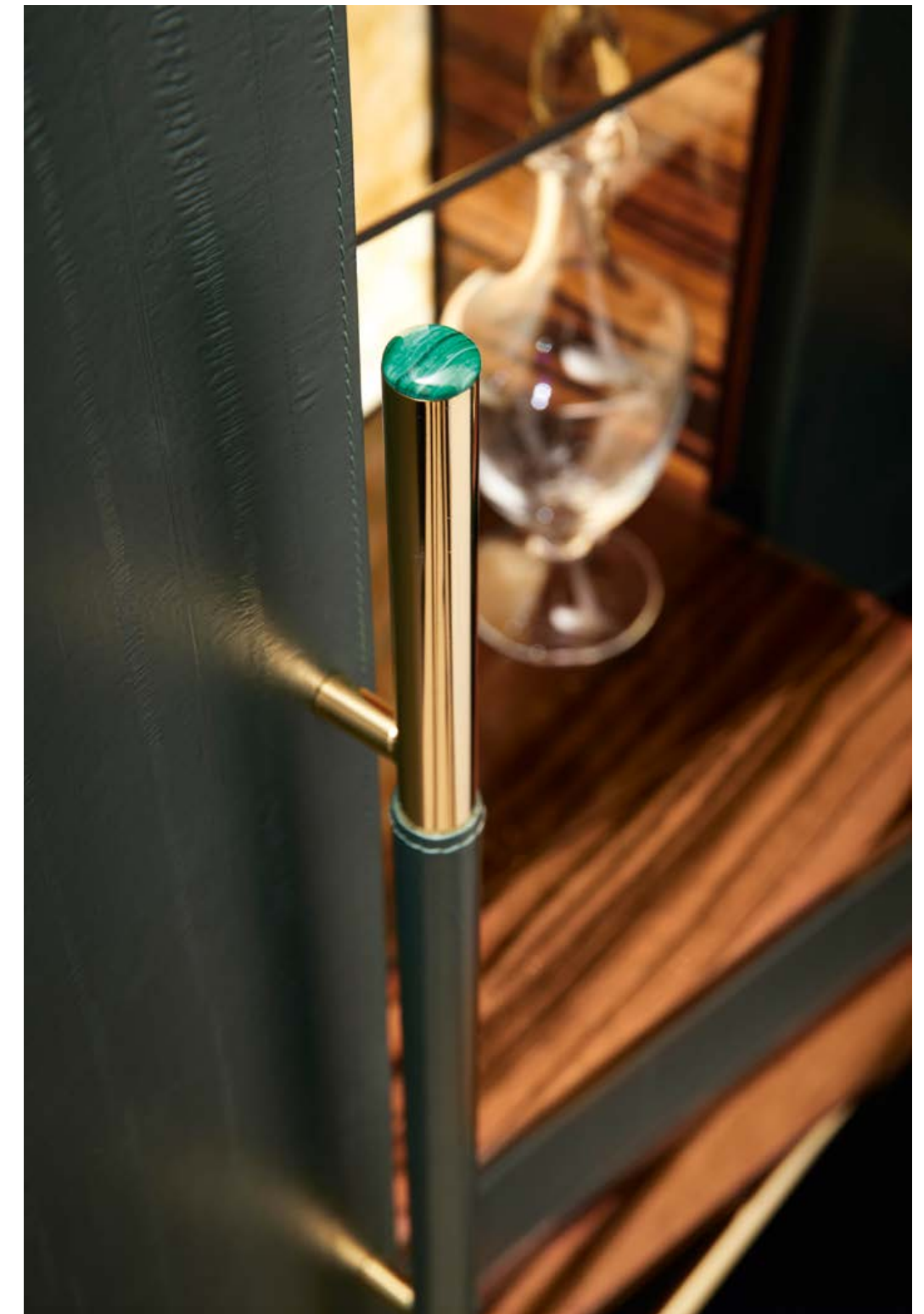

**Baron** Bar cabinet / Mobile Bar

Every detail highlights the great craftsmanship of the product. Luxury is made of details.  
Ogni particolare denota la grande artigianalità del prodotto. Il lusso è fatto dai dettagli.

The Rebel sofa is a project born from a detail: the plissè, which is highlighted on the armrest of the seats. Light, airy, elegant and welcoming, the aim was to give importance, character, personality and richness to the padded product.

A richness that can be appreciated through touch and use, thanks to the choice of precious raw materials, worked by expert hands and through a know-how that comes from consolidated expertise in the universe of wellness and upholstery.

Il divano Rebel è un progetto nato da un dettaglio: il plissé, che viene messo in grande risalto sul bracciolo delle sedute.

Leggero, aereo, elegante e accogliente, si è voluto dare importanza, carattere, personalità, ricchezza al prodotto imbottito.

Una ricchezza che si apprezza con il tatto e l'uso, grazie alla scelta di materie prime pregiate, lavorate da mani esperte e attraverso un knowhow che arriva da un'expertise consolidata nell'universo del benessere e degli imbottiti.



**Rebel** Sofa / Divano

The sofa's theme of painted metal tubing, the collection's leitmotif, creates the supporting structure for the soft padding.

E' ripreso il tema del tubolare di metallo verniciato, il rouge della collezione, il tubolare di metallo verniciato, crea la struttura portante per le morbide imbottiture.

**Evy** Madia

The design of the sideboard is dressed with a different finish, briar.

Il design della madia viene vestito con una finitura diversa, la radica.





In the living space the sofa takes on the role of a natural center of gravity, giving the environment the atmosphere we desire for our living. Inspired by lightness but made concretely, the models in the collection aim to give the home space true design: one in which elegance and function always go hand in hand. Tool of our daily rituals, they must convey a unique experience of relaxation and well-being. Designed with Italian aesthetics and elegance, Rebel offers exceptional functionality and comfort. Made with high quality materials and artisan techniques, it guarantees great comfort over time.

Nello spazio living il divano assume il ruolo di centro di gravità naturale, conferendo all'ambiente l'atmosfera che desideriamo per il nostro abitare. Ispirati alla leggerezza ma realizzati nella concretezza, i modelli della collezione vogliono regalare allo spazio di casa il vero design: quello in cui eleganza e funzione viaggiano sempre di pari passo. Strumento dei nostri riti quotidiani, devono trasmettere un'esperienza unica di relax e benessere. Disegnato con estetica ed eleganza italiana, Rebel offre funzionalità e comfort eccezionali. Realizzato con materiali di alta qualità e tecniche artigianali, garantisce nel tempo grande confort.







**Rania** Armchair / Poltrona

The armrest's pleated detail and the prestigious finishes characterise the upholstered collection. Nothing is left to chance.

Il dettaglio plissettato del bracciolo e le finiture prestigiose caratterizzano la collezione imbottiti. Nulla è lasciato al caso.



Constantly seeking the equation between uniqueness and sartorial, elegant, welcoming and familiar cut, the Rebel upholstered furniture collection stands out for its sensual style and for the accurate ribbed workmanship on the armrest, details that make them small works of upholstery. The combination is perfect with the low tables with a nomadic allure which feature the characteristic base in painted metal tubing with a leather-covered base. Increasingly sophisticated research into processes and materials and new product types open up new frontiers and prestigious collaborations.

Alla costante ricerca dell'equazione tra unicità e taglio sartoriale, elegante, accogliente e familiare, la collezione di imbottiti Rebel si distingue per il segno sensuale e per le accurate lavorazioni canneté sul bracciolo, dettagli che ne fanno piccole opere di tappezzeria. Perfetto l'abbinamento con i tavoli bassi dall'allure nomade che ripropongono la caratteristica base in tubolare di metallo verniciato con base rivestita in pelle. Una ricerca sempre più sofisticata su lavorazioni e materiali e nuove tipologie di prodotto aprono inedite frontiere e prestigiose collaborazioni.





**Talis** Low table / Tavolo basso

Low tables of various shapes and sizes, versatile in various combinations of materials, in a simple and measured correlation of balance and proportions.

Tavoli bassi di diverse forme e dimensioni, versatili e realizzabili in varie combinazioni di materiali in un rapporto semplice e misurato di equilibrio e proporzioni.





Low table / Tavolo basso

Matchable with each other, not only in shape but also in finish, the collection's low tables are the right complement to the collection's various elements.

Abbinabili tra loro, non solo per forma ma anche per finitura, si tavoli bassi della collezione sono il giusto complemento ai vari elementi della collezione.

**Talis**



**Tobia** Low table / Tavolo basso

The tables are micro-architectures that adapt to the home's various areas, complements to be interpreted according to the spaces. The simplicity of the lines is expressed through precious materials and careful workmanship.

I tavolini sono delle micro architetture che si adattano alle diverse zone della casa, complementi da interpretare a seconda degli spazi. L'essenzialità delle linee si esprime attraverso materiali pregiati e lavorazioni accurate.

**Tobia** Low table / Tavolo basso

The contemporary home requires flexibility, even in its details, and durability. The Tobia table, in the elliptical version of timeless elegance, is a discreet companion to everyday life, like all the others in the collection; elegant like jewellery, their design and the choice of finishes aims to underline this similarity.

La casa contemporanea richiede flessibilità, anche nei dettagli, e durabilità. Il tavolo Tobia nella versione ellittica, di eleganza intramontabile, è un compagno discreto del quotidiano, come tutti gli altri della collezione; eleganti come gioielli, il loro design e la scelta delle finiture mira a sottolineare questa similitudine.





**Tobia** Low table / Tavolo basso

An architecture, an acrobatics of proportions, an intersection of joints. An infinite coffee table, a geometric dialogue between metal and ebony, a distillation of lightness and abstraction.

Un'architettura, un'acrobazia di proporzioni, un incrocio di incastri. Un tavolino infinito, un dialogo geometrico tra il metallo e l'ebano, un distillato di leggerezza e di astrazione.

Materials, colors and geometric lines intertwine with décor, art dialogues with technology creating new settings and sensorial stimuli.

Former In Italia continues to interpret the transformation of the home into an increasingly flexible and multitasking place, the theater of new lifestyles. The sideboards are essential complements in the living area, to which the utmost attention to detail is dedicated: from the shelves that seem to float inside the volume, to the curved sides shapes with a sophisticated allure, from the base that becomes an aesthetic peculiarity to the specially developed hinge.

Materiali e colori raccontano di geografie vicine e lontane, le linee geometriche si intrecciano con il décor, l'arte dialoga con la tecnologia creando nuove ambientazioni e stimoli sensoriali.

Former In Italia continua a farsi interprete della trasformazione della casa in un luogo sempre più flessibile e multitasking, teatro di nuovi stili di vita. Le madie sono complementi immancabili nella zona giorno, a cui è dedicata la massima attenzione ai dettagli: dai ripiani che sembrano galleggiare all'interno del volume, ai fianchi curvi dall'allure sofisticata, dal basamento che diventa peculiarità estetica alla cerniera sviluppata ad hoc.



**Madia / Madia Evy**

Research and experimentation are at the base of this refined and complex sideboard. In addition to its clean and elegant appearance it hides particular and refined interiors. A rich and multifaceted collection to satisfy the public's various tastes.

Ricerca e sperimentazione alla base di questo mobile madia ricercato e complesso che, oltre all'aspetto pulito ed elegante, nasconde interni particolari e ricercati. Una collezione ricca e sfaccettata per soddisfare i diversi gusti del pubblico.





**Evy**  
**Madia / Madia**

Precious objects, made of contours, bevels, joints and passages of materials which, together, constitute poetic perfection and detail. The top of all the collection's elements is contoured, narrowing in the central part while opening up at the sides.

Oggetti preziosi, fatti di sagome, smussi, attacchi e passaggi di materie che, nell'insieme, costituiscono una poetica della perfezione e del dettaglio. Il piano di tutti gli elementi della collezione è sagomato, restringendosi nella parte centrale e aprendosi ai lati.

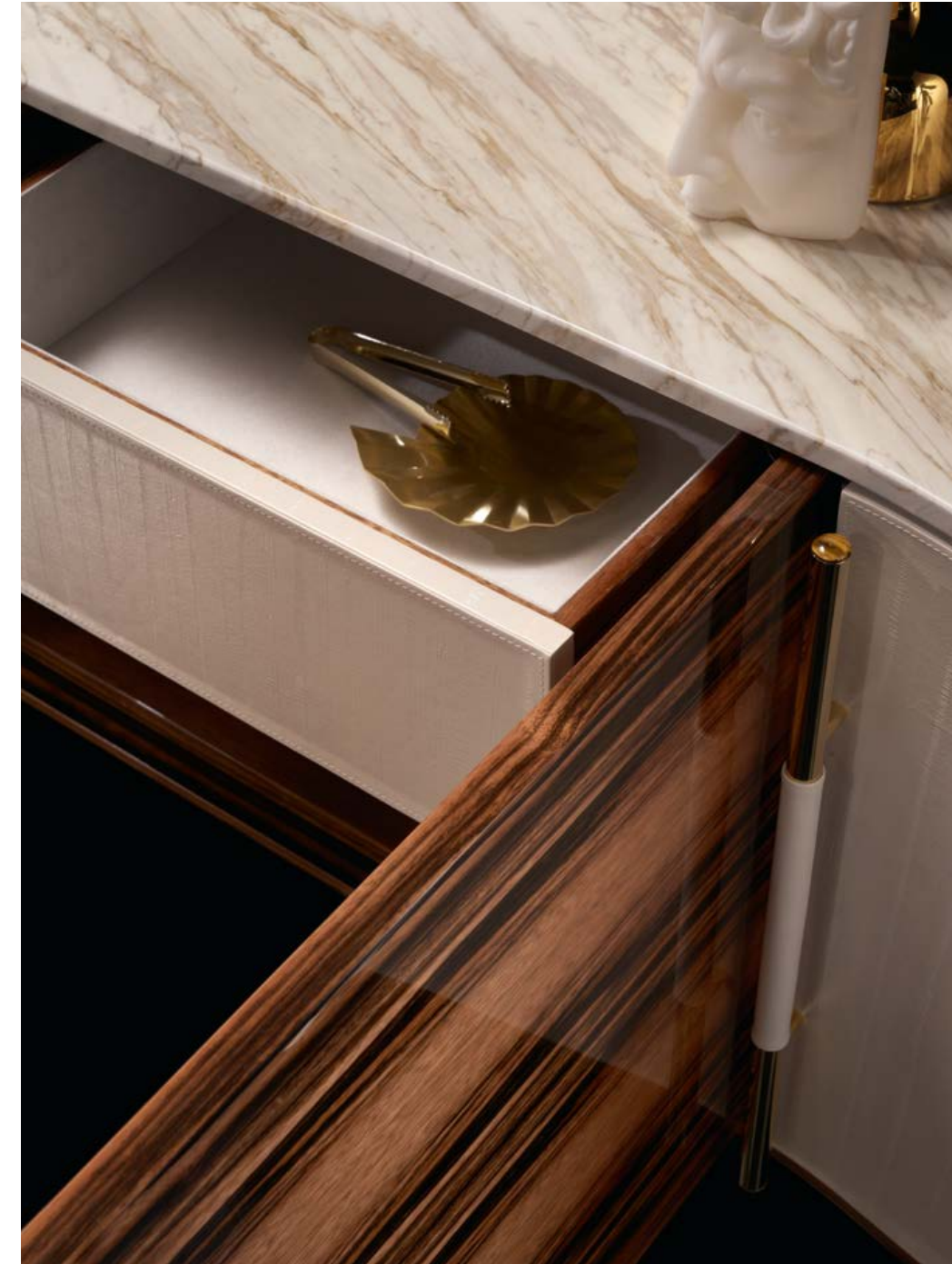

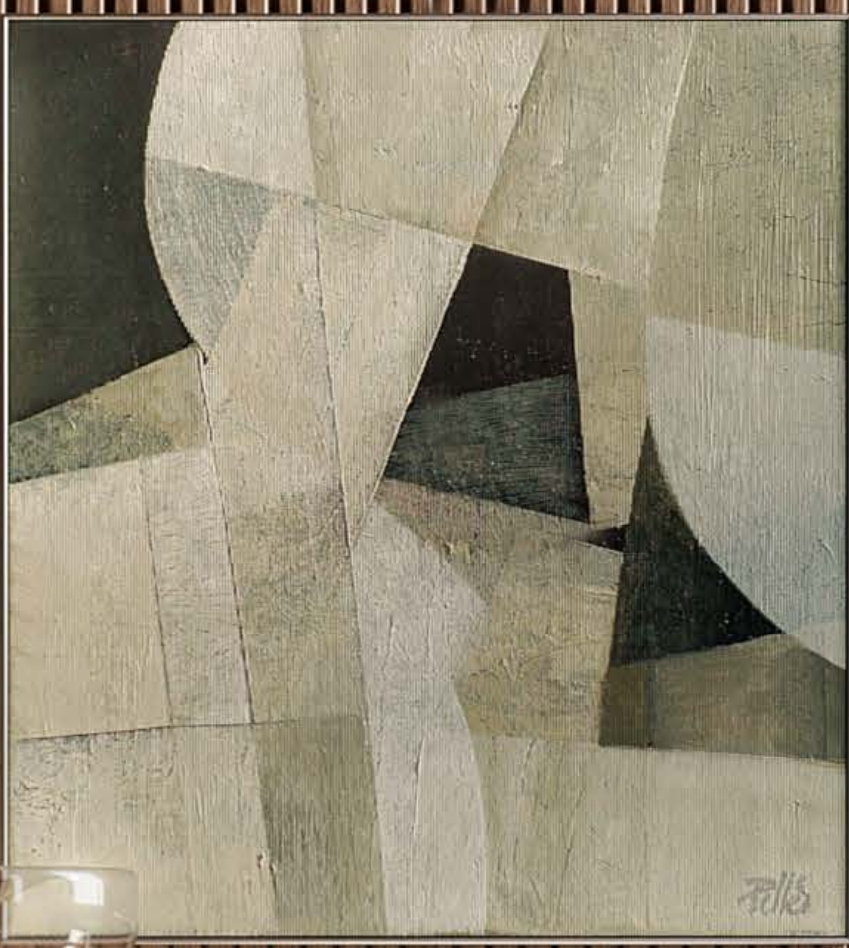

Alvaro Siza Indiscipline  
EAT DRINK NAP



**Evy** Madia / Madia

The central part is embellished with a glossy paint in contrast to the leather-covered side doors, while the top can be customized in marble or wood. The top is slightly embossed at the lateral ends, a peculiarity that accentuates its singularity. In the center there is an open compartment whose volume gives the piece a sense of movement.

La parte centrale è impreziosita da una verniciatura lucida in contrasto alle ante laterali rivestite in pelle, mentre il top è personalizzabile in marmo o legno. Il piano è leggermente sbalzato alle estremità laterali, peculiarità che accentua la sua singolarità. Al centro si trova uno scomparto aperto il cui volume regala al pezzo un senso di movimento.

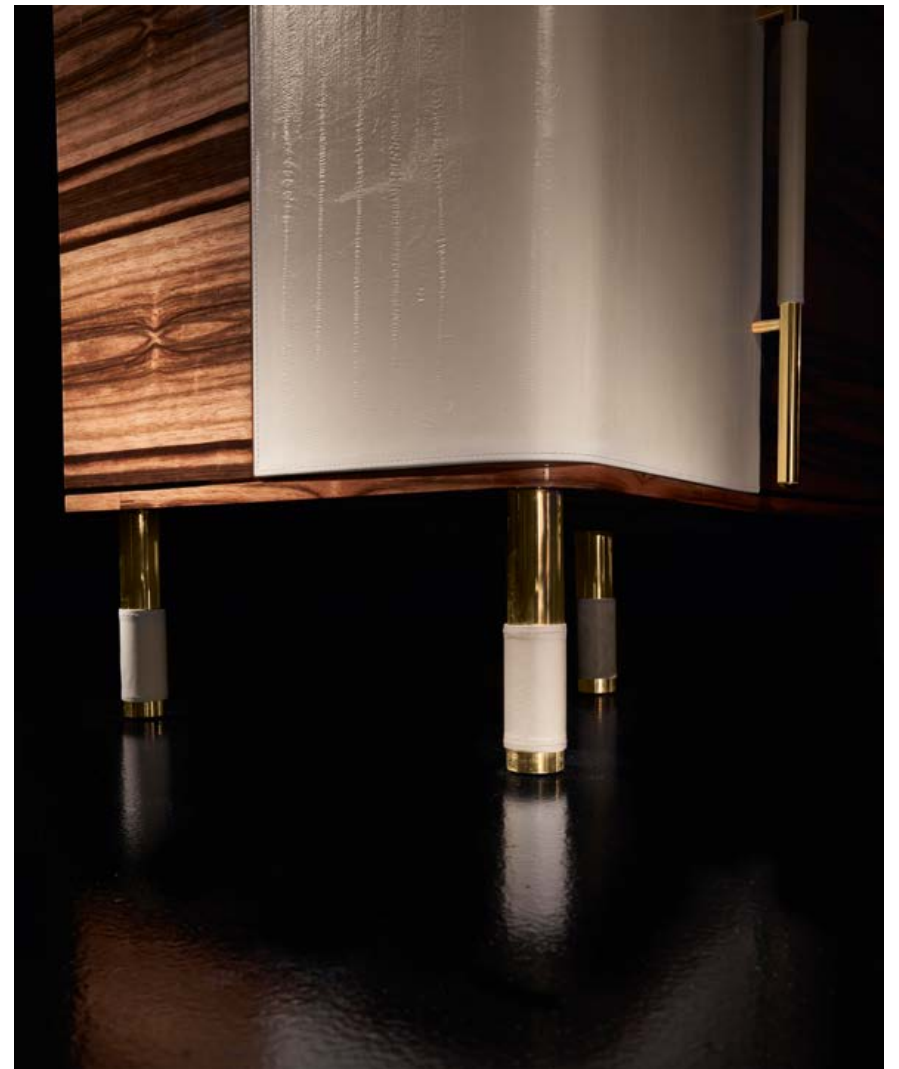

Versatile products with an elegant and decisive character, never conventional, which stand out for the very high quality of the materials, for the tailored workmanship and for an obsessive research on finishes, shapes, textures and colours. Clean shapes, attention to detail, research into furnishing materials that outline a dynamic and welcoming domestic landscape. Elegance, lightness, great comfort, enveloping lines reinterpreted in a contemporary key. Tradition and innovation, in the Former In Italia style.

Prodotti versatili dal carattere elegante e deciso, mai convenzionale, che si contraddistinguono per l'altissima qualità dei materiali, per le lavorazioni sartoriali e per una ricerca maniacale su finiture, forme, texture e colori. Pulizia delle forme, attenzione per il dettaglio, ricerca sui materiali per arredi che delineano un paesaggio domestico dinamico e accogliente. Eleganza, leggerezza, grande comfort, linee avvolgenti reinterpretate in chiave contemporanea. Tradizione e innovazione, nello stile Former In Italia.





### Svevo

Desk / Scrivania

Its elegant and modern silhouette makes it an element of strong impact. The clean lines of the desk and the play between the different thicknesses of the structure and handles give it a contemporary tasteful minimalist appearance.

La sua silhouette elegante e moderna lo rende un elemento di forte impatto.

Le linee pulite dello scrivania e il gioco tra i diversi spessori della struttura e delle maniglie le conferiscono un aspetto minimalista dal gusto contemporaneo.

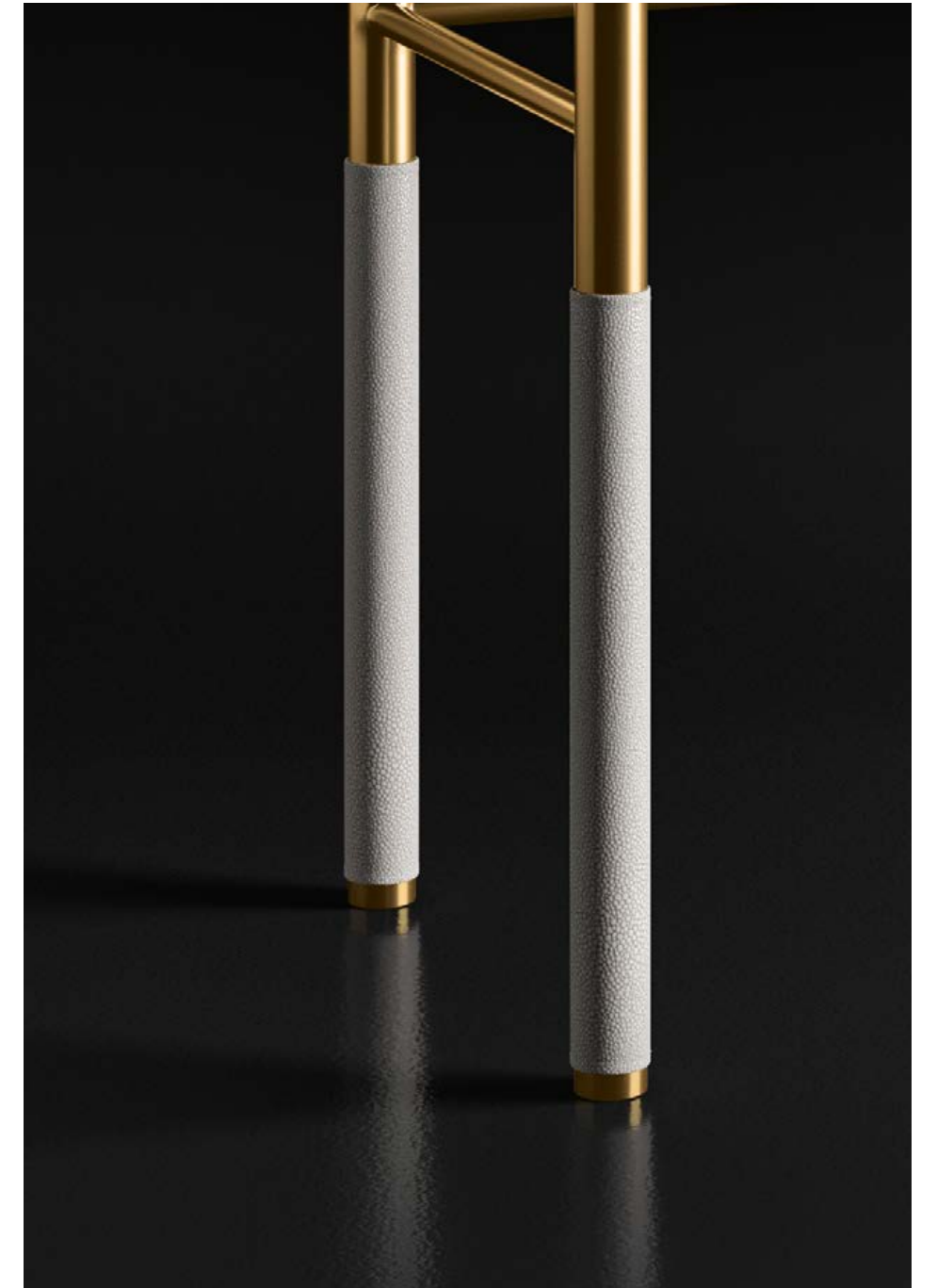

Low, jewelled tables that are crafted using special details and materials designed with absolute visual and constructive simplicity, in the most natural way for a craftsman to put different materials.

Definable as small stages, full of attention and details, these tables tell of great passion for quality and detail.

Un'evoluzione che racconta una visione dell'abitare fluida e trasversale che include collezioni diverse ma tutte intersificabili le une alle altre in un insieme raffinato e ricercato.

Oggetti - gioiello lavorati con dettagli e materiali importanti, progettati con una semplicità visiva e costruttiva assoluta, nel modo più naturale che ha un artigiano di mettere insieme diversi materiali. Definibili come piccoli palcoscenici, ricchi di attenzioni e dettagli, questi mobili raccontano di grande passione per la qualità e per il dettaglio. Un'evoluzione che racconta una visione dell'abitare fluida e trasversale che include collezioni diverse ma tutte intersificabili le une alle altre in un insieme raffinato e ricercato.





Consolle / Consolle

A monolith with stylised and geometric shapes to be interpreted freely, choosing among all the possibilities offered by the combinations of finishes, essences and marbles.

Un monolite dalle forme stilizzate e geometriche da interpretare in libertà, scegliendo tra tutte le possibilità offerte dagli abbinamenti di finiture, essenze e marmi.

### Minia





### **Minia** Consolle / Consolle

The Mina console has a modern design that echoes the characterizing lines of the collection, with a structure partially covered in leather which creates, with the marble top, an original alternation of materials. The console has small dimensions; the bright gold painting highlights its shapes.

La consolle/scrittoio Svevo ha un design moderno che richiama le linee caratterizzanti della collezione, con struttura parzialmente rivestita in pelle che crea, con il piano in marmo, un'originale alternanza di materiali. La consolle ha dimensioni contenute; la verniciatura in oro brillante ne sottolinea le forme.

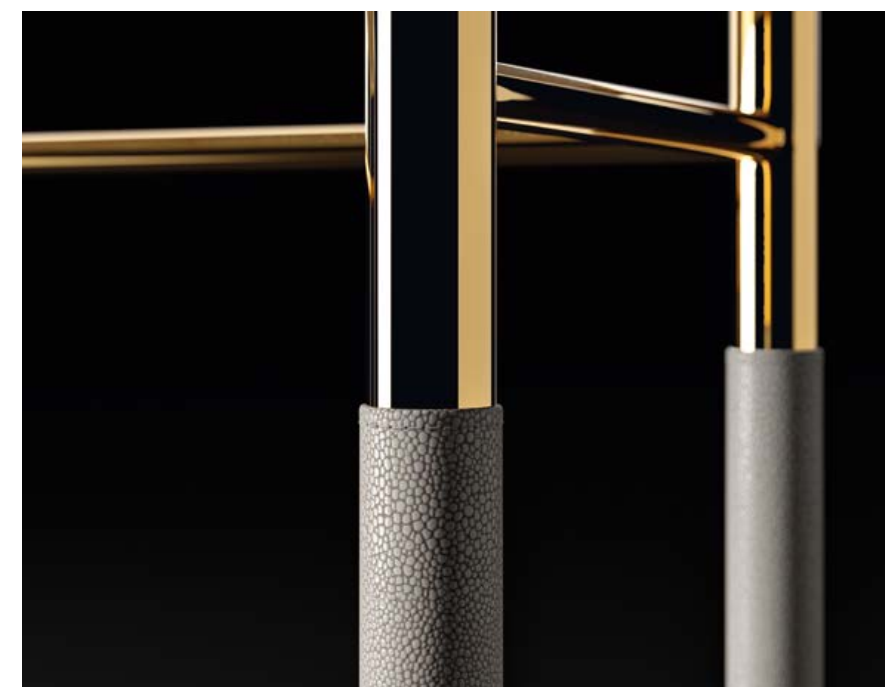

The sleeping area is a sort of kaleidoscope that brings with it a memory of Former In Italia workmanship and products. A collection characterized by a wealth of products offered in a single mood divided into a range of objects that allows them to be inserted into any type of context which invites relaxation and ensures the highest quality of life and spaces. The Rebel bedroom is the environment in which functionality and aesthetics find the perfect balance, where the desire to overcome borders with an international, defined, cosmopolitan style is evident.

La zona notte è una sorta di caleidoscopio che porta con sé la memoria delle lavorazioni e dei prodotti Former In Italia. Una collezione caratterizzata da una ricchezza di prodotti proposti in un'unico mood declinato in un range di oggetti che ne permette l'inserimento in ogni tipo di contesto, che invita al relax e assicura la massima qualità di vita e degli spazi. La camera da letto Rebel è l'ambiente in cui funzionalità ed estetica trovano il perfetto equilibrio, e dove appare evidente la volontà di superare i confini con uno stile internazionale, definito, cosmopolita.



**Silea**  
Chest of Drawers / Comò

**Monolith**  
Bed / Letto

**Kikko**  
Nigh table / Comodino

**Aliseo**  
Mirror / Specchio

An important piece, intentionally large and comfortable, capable of enriching the bedroom's style with its contemporary design which combines essential lines, harmonious proportions and refined details.

Un pezzo importante, volutamente ampio e comodo in grado di arricchire lo stile della camera da letto con il suo design contemporaneo che unisce linee essenziali, proporzioni armoniose e dettagli raffinati.





Bedside table / Comodino

**Kikko**

Rigorous and minimalist project designed to complement the Monolith bed with functionality. Bedside table with drawer; an important aggregating point of the sleeping area.

Progetto rigoroso e minimalista studiato per affiancare con funzionalità il letto Monolith. Comodino con cassetto, è un importante punto di aggregazione della zona notte.





Aiming to offer a complete, elegant and functional living concept, in the last few seasons Former In Italia has been defining its own lifestyle through a series of refined décor objects. The mission is to put the customer at the centre, enabling them to benefit from our original solutions that combine aesthetics and functionality.

Con l'idea di proporre un concept abitativo completo, elegante e funzionale, da qualche stagione Former In Italia definisce il proprio lifestyle attraverso proposte che si declinano in una serie di raffinati oggetti per il décor. La missione vede al centro il cliente e la capacità di premiarlo con un servizio unico attraverso soluzioni che sappiano promuovere non solo la bellezza ma anche la funzionalità.





**Aliseo** Mirror / Specchio

Soft and sinuous shapes for a mirror that reflects both dreams and the sky, linked to the collection thanks to its design and finishes.

Supported by two uprights that allow it to oscillate, the Aliseo mirror has a clean and sharp design that highlights the wood finish

Forme morbide e sinuose per uno specchio che riflette sogni e cielo, legato alla collezione per design e finiture. Sorretto da due montanti che ne permettono l'oscillazione, lo specchio Aliseo ha un design pulito e netto che mette in risalto la finitura del legno.





**Blasy** Vanity desk

This precious bedroom vanity contains all the features and precious details of the collection. Precious coverings also for the internal drawers, divided into small compartments.

Prezioso mobile toilette da camera, racchiude in sé tutte le caratteristiche e i dettagli preziosi della collezione. Preziosi rivestimenti rivestono anche i cassetti interni suddivisi in piccoli scomparti.



Vanity desk

A piece that can hardly be classified.  
It's not a sideboard, container or desk: it's a bit of all  
these things. A mysterious piece of furniture, a treasure  
chest of secrets and magic.

E' un pezzo che difficilmente può essere classificato.  
Non è una credenza, non è un contenitore, non è  
una scrivania: è un po' tutte queste cose. Un mobile  
misterioso, uno scrigno custode di segreti e di magie.

## Blasy





### Blasy Vanity desk

Leather with a "stingray pattern" is a strong, unique and immediately recognizable sign that does not remain tied to a single object, rather it becomes the main theme of an entire collection. The combination with the ebony essence is the perfect match.

La pelle con disegno "razza" è un segno forte, unico e immediatamente riconoscibile che non resta legato a un singolo oggetto, ma diventa il tema portante di una intera collezione. L'accostamento all'essenza ebano è l'abbinamento perfetto.





Vanity desk

**Blasy**

Elegant like jewellery, the collection's details are inspired by the cuts of the precious stones mounted on the rings. The choice of finishes aim to underline this similarity.

Eleganti come gioielli, i dettagli della collezione si ispirano ai tagli delle pietre preziose montate sugli anelli. La scelta delle finiture mira a sottolineare questa similitudine.



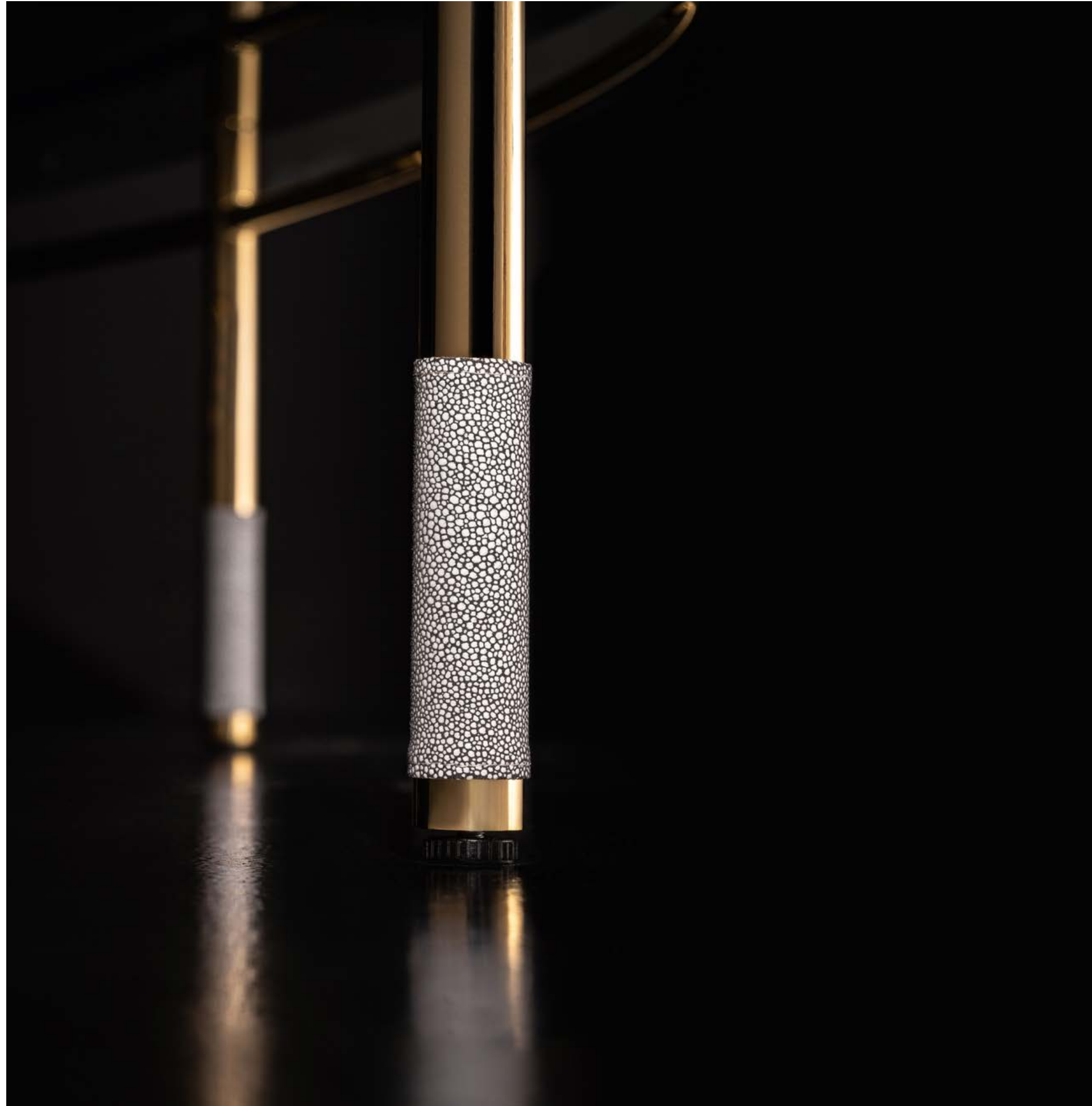

**Blasy** Vanity desk

The beauty of the object is developed in a play of gentle symmetries and precious details, evidence of craftsmanship that is difficult to find nowadays.

La bellezza dell'oggetto si sviluppa in un gioco di gentili simmetrie e dettagli preziosi, testimoni di una manualità oramai introvabile.



### Svevo Scrittoio / Desk

The Blasy desk, with front, base and side in a precious briar wood finish, has as its spirit not only the search for aesthetics but also the recovery of a ritual scenario of working: a small and precious domestic workstation capable of adapting to the style of the modern life.

Lo scrittoio Blasy, con frontale, base e fianco in preziosa finitura di radica, ha come spirito non solo la ricerca dell'estetica ma anche del recupero di un scenario rituale del lavorare: una piccola e preziosa postazione domestica in grado di adattarsi allo stile della vita moderna.





**Silea** Comò / Chest of Drawers

Three large, full-width drawers cut the volume of the dresser horizontally; the precious handles mark the longitudinal rhythm by focusing on the protrusion of the top.

Tre ampi cassetti in tutta larghezza tagliano orizzontalmente il volume del comò; le preziose maniglie scandiscono il ritmo longitudinale focalizzando lo scanso del piano.



Former In Italia is defined by a high-end design made in Italy, to offer the best comfort for resting in total relaxation.

A collection that gives an atmosphere of intimacy to the sleeping area with elegance and a touch of modernity.

Materials and colors intertwine creating a perfect harmony of elements, suitable for both classic and modern environments.

The metal base is a reference to the design language of the entire collection.

Former In Italia si definisce per un design di fascia alta made in Italy, per offrire il miglior comfort per riposare in totale relax.

Una collezione che dona un'atmosfera di intimità alla zona notte con eleganza e un tocco di modernità.

Materiali e colori s'intrecciano creando una perfetta sintonia di elementi, adatta ad ambienti sia classici che moderni.

Il basamento in metallo è il richiamo al linguaggio progettuale di tutta la collezione.





**Silea** Chest of Drawers / Comò

Elegance in expertly crafted shapes: handles and bases are the foundation of the entire collection's design language.

Eleganza in forme elegantemente ricercate: maniglie e basamenti sono alla base del linguaggio progettuale di tutta la collezione.





Chest of Drawers / Comò

**Silea**

A richness that can be appreciated with touch and use, thanks to the choice of fine raw materials, crafted by expert hands through consolidated know-how in the universe of well-being.

Una ricchezza che si apprezza con il tatto e l'uso, grazie alla scelta di materie prime pregiate, lavorate da mani esperte e attraverso un knowhow consolidato nell'universo del benessere.



Since 1970 creativity, style and design have expressed the company's know-how. Former In Italia has always operated with a view to sustainability, reconciling ecological awareness with production needs and with respect and care for the people who work in the company. Experience on customized products and industrial precision in serial production merge today in our production reality, enhancing the quality and flexibility of production. The best quality materials blend with design and technology.

Dal 1970 creatività, stile e design raccontano il know-how dell'azienda. Former In Italia opera da sempre nell'ottica della sostenibilità, conciliando la coscienza ecologica con le esigenze produttive e con il rispetto e la cura delle persone che lavorano in Azienda.

L'esperienza sul prodotto su misura e la precisione industriale nelle realizzazioni seriali si fondono oggi nella nostra realtà produttiva, esaltando la qualità e la flessibilità della produzione.

I materiali della migliore qualità si fondono con il design e la tecnologia.

## Technical details The world of the materials

The products presented in this catalog have been designed with our Italian taste, but it is possible to customize finishes and materials to interpret Former In Italia an original way, creating new furnishing proposals in line with the trends of the design world.

Former In Italia bespoke: Thanks to our special project division, we are able to collaborate with designers and architects for the development and production of luxury interiors.

I prodotti presentati in questo catalogo sono stati pensati con il nostro gusto italiano, ma è possibile personalizzare finiture e materiali per interpretare Former In Italia in modo originale, creando nuove proposte di arredo in linea con le tendenze del mondo del design.

Former In Italia bespoke: grazie alla nostra divisione speciale per i progetti, siamo in grado di collaborare attivamente con designers e architetti per lo sviluppo e la produzione di interni di lusso.

# Paints



GOLD



BRONZE



BLACK



CHROME shiny

# Cabochons - precious stones

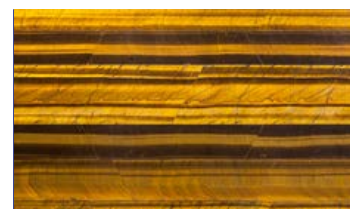

OCCHIO DI TIGRE

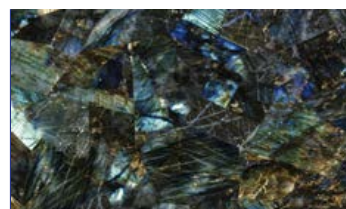

LABRADORITE

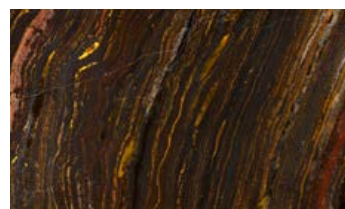

IRON EYE



MALACHITE

IT Le foto qui proposte sono da ritenersi indicative. Marmo e legno sono prodotti naturali e le loro caratteristiche venature e colori possono variare. E' possibile richiedere foto dell'attuale disponibilità a magazzino di blocchi di marmo ed impiallacciate contattando i nostri uffici. Le essenze possono avere finitura poro aperto o chiuso, verniciati opachi o lucidi con Gloss da definire; specificare al momento dell'ordine la propria preferenza.

EN These pictures are meant to be a general idea of the marbles and of the wood finishes. Since wood and marble are natural materials, the colorshades and veins may vary a bit depending on the slabs and veneerings available at the moment. In order to have a look at the availability it is possible to ask for pictures to our office. Wood finishes can come with open or close pore, and be painted with matt or shiny finish, Gloss to be specified at the moment of the order.

# Galvanic treatments

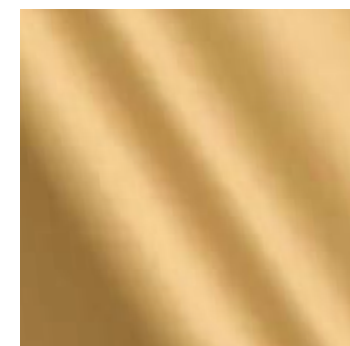

ORO 24K

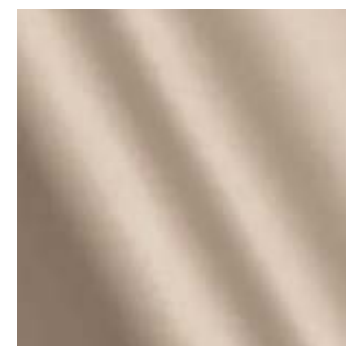

ORO CHAMPAGNE

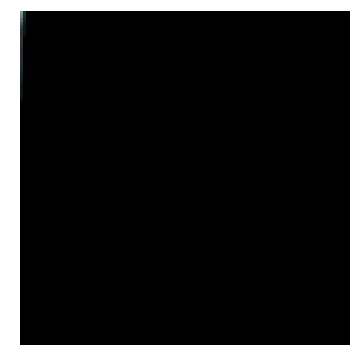

CHROMO nero



CHROMO lucido

# Glasses



BACK LACQUERED GLASS dark grey

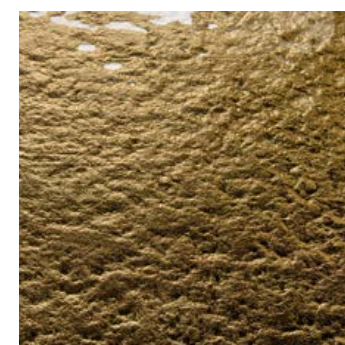

BACK LACQUERED GLASS bronze

# Essences



10.03 ERABLE FRISÉ TINTO NOCE



EBONY dark

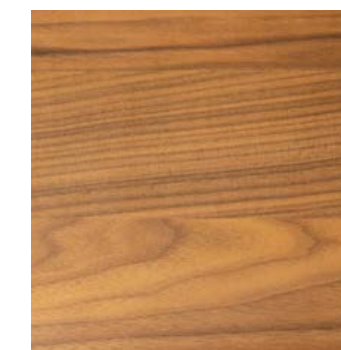

NOCE CANALETTO

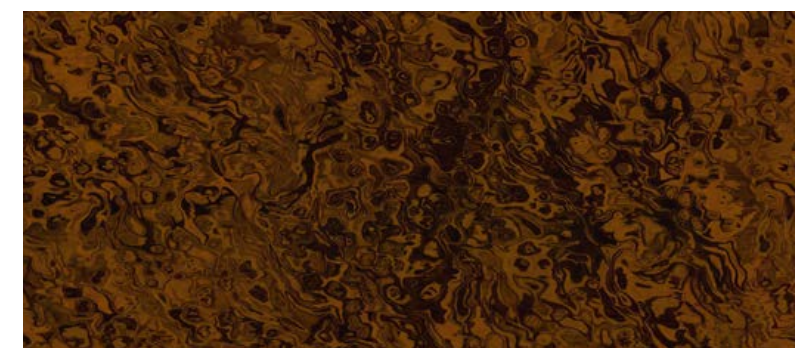

10.06 CALIFORNIA BURL CHOCOLATE



PALISSANDRO SANTOS

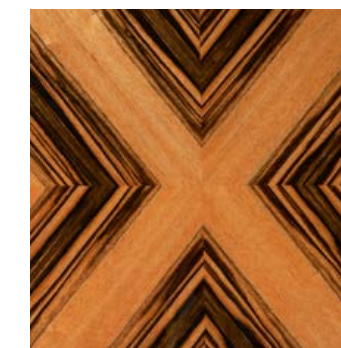

EBONY EMARA with herringbone pattern



EBONY EMARA



ZEBIRANO



DARK OAK

# Marbles

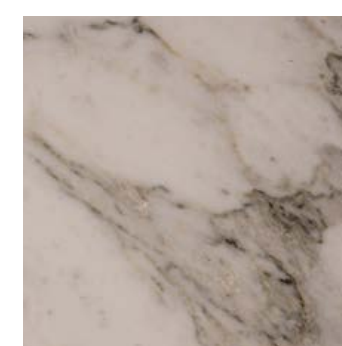

CALACATTA white

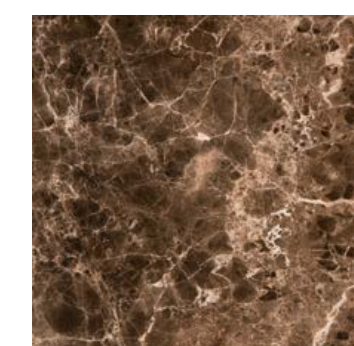

EMPERADOR dark

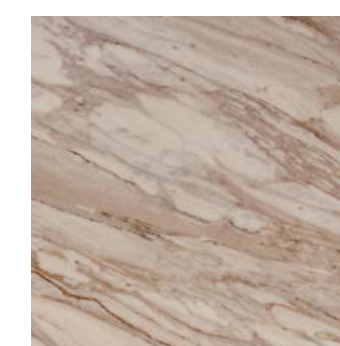

VOLAKAS

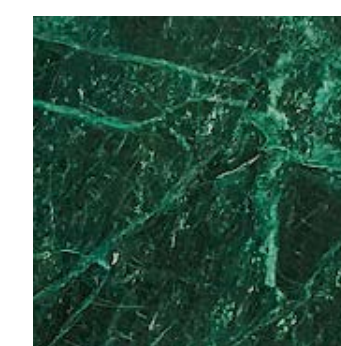

VERDE GUATEMALA



PORT LAURENT Damascus rose

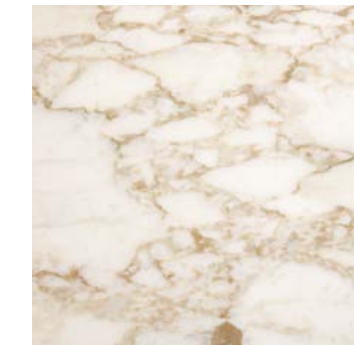

CALACATTA gold



TRAVERTINO

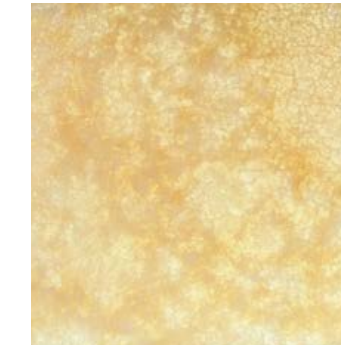

ONICE

## Evy Madia

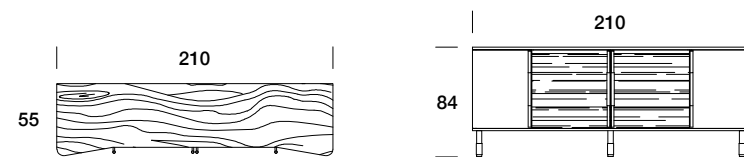

Mobile madia con interni, fianchi, schienale e ante centrali interamente realizzati in legno listellare impiallacciato verniciato lucido (100% Gloss). Struttura in tubolare di acciaio con verniciatura galvanica resistente alla corrosione. Inserti decorativi in pelle. Lateralini con ante stondate all'estremità e completamente rivestite in pelle, fornite di cerniere antirullo; ripiani interni caratterizzati da ripiani in vetro bronzato mm 5, anch'essi sagomati. Top in marmo dallo speciale disegno senza angoli acuti nella parte frontale e rientrante nella parte centrale dove sono celati due cassetti dal frontale rivestito in pelle ed interno rivestito in microfibra in un colore in tinta. Fianchi cassetti impiallacciati. Maniglie in acciaio inox parzialmente rivestite in pelle con cabochon in pietra preziosa.

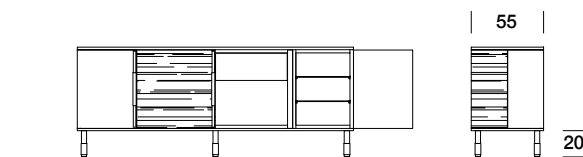

Curved doors upholstered with leather on both the inside and outside. Credenza made of blockboard with Ebano Emara veneering 100% Gloss on the central doors, on the inside and on the back and half of the sides. Volakas marble top featuring a special design without acute angles on the frontal side. Internal sides featuring 5 mm bronzed-glass shelves, moulded as per side's design. Central compartment featuring two drawers whose frontal is upholstered with leather, inside of the drawers upholstered with matching color microfiber. Sides of drawers fully veneered. Stainless steel handles upholstered with leather, cabochon on the top and on the bottom of the handle made of precious stone to be chosen among: Tiger Eye, Malachite, ... Steel legs upholstered with leather. Marble top. Upon request: Calacatta, Onix, Travertino, Emperador, other marbles available upon request: veneerings: Noce Canaletto, dark oak, ...

## Baron Bar Cabinet



Mobile bar con interni, fianchi e schienale interamente realizzati in legno listellare impiallacciato e verniciato lucido (100% Gloss). Struttura in tubolare di acciaio con verniciatura galvanica resistente alla corrosione con inserti decorativi in pelle. Ante curvate sugli angoli esterni - a richiamare le rotondità del disegno del top - rivestite sia internamente che esternamente in pelle. Ripiani interni in vetro bronzato mm 8. Cassetto interno con frontale rivestito in pelle ed interno rivestito in microfibra, colore in tinta. Fianchi dei cassetti impiallacciati. Maniglie in acciaio inox parzialmente rivestite in pelle, cabochon in pietra preziosa. Su richiesta le seguenti opzioni per lo schienale interno:  
- rivestito in pelle / illuminazione a faretti (led?)  
- impiallacciato / illuminazione a faretti (led?)  
- marmo retroilluminato.

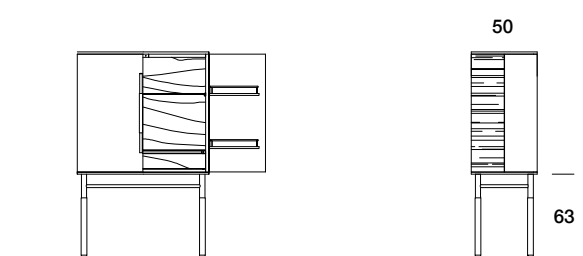

Bar unit made of blockboard veneered all over with Ebony Emara, 100% Gloss. Wooden doors upholstered with leather inside and outside. Internal shelves made of 8 mm glass with bronze finish. Shelves on the doors made of blockboard wood veneered all over, featuring a curved design to match the curved shape of the door itself; anti-roll bar made of stainless steel. Drawer with Ebano Emara veneering all over, internal covered with microfiber, drawer's frontal upholstered with leather. Handles made of stainless steel and upholstered with leather featuring cabochon on both the top and the bottom made of precious stones to be chosen among Tiger's eye, Malachite, ... Legs and base made of steel, legs upholstered with leather. Upon request: internal back made of back-lighted marble, or veneered and with spotlights, or lacquered.

## Minia Consolle

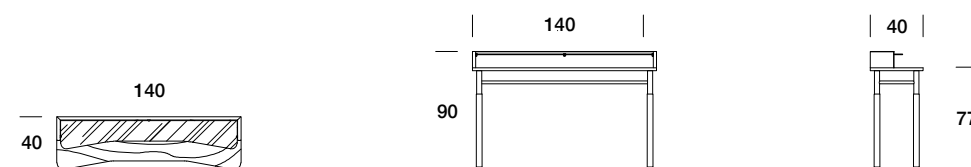

Mobile consolle realizzato in legno listellare impiallacciato e verniciato lucido (100% Gloss). Struttura in tubolare di acciaio con verniciatura galvanica resistente alla corrosione con inserti decorativi in pelle. Piano in marmo sagomato rientrante al centro, ripiano in vetro temperato mm. **manca**. Sottotop in legno laccato 100% Gloss.

Made of blockboard with Ebony Emara veneerings, 100% Gloss. Volakas marble top and tempered glass shelf. Undertop made of 100% Gloss lacquered wood. Legs and base made in stainless steel, with leather upholstery.

## Tablò dining Table

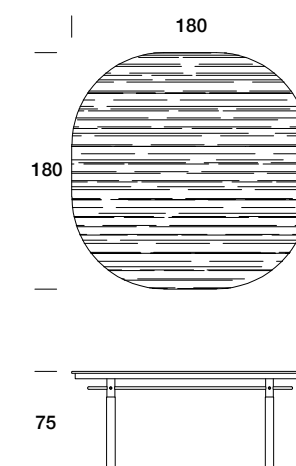
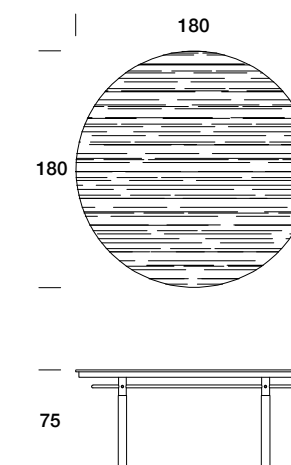
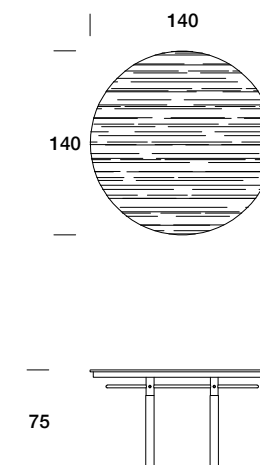
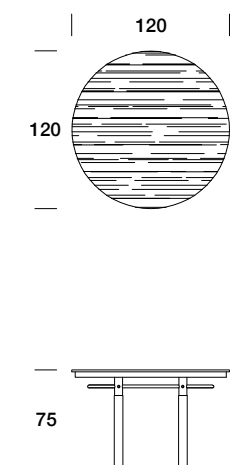
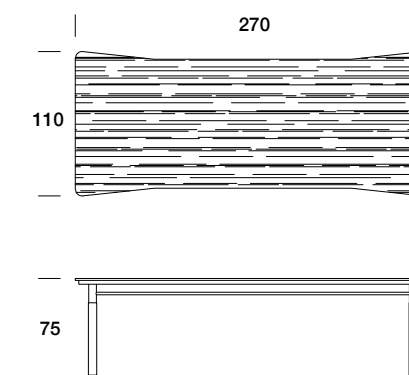
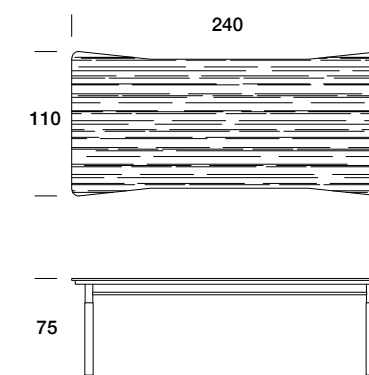

Tavolo con struttura in tubolare di acciaio con verniciatura galvanica resistente all'ossidazione e alla corrosione con inserti decorativi in pelle. Piano in marmo e sottotop in legno con bordo laccato 100% Gloss.

Marble top, undertop made of wood with lacquered sides 100% Gloss. Legs and base made of stainless steel, legs upholstered with leather.

## Tablò dining Table

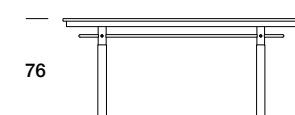
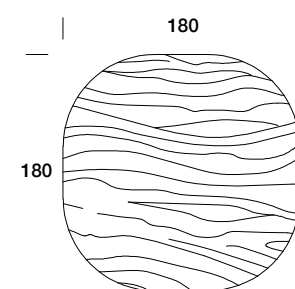
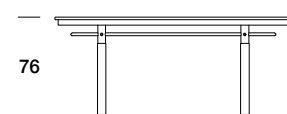
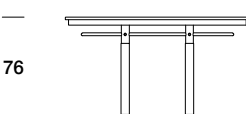
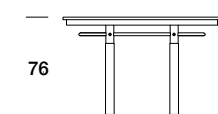
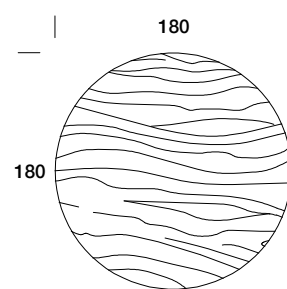
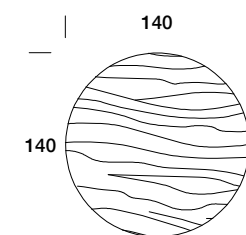
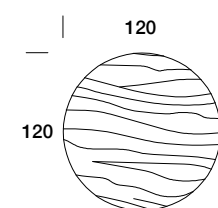
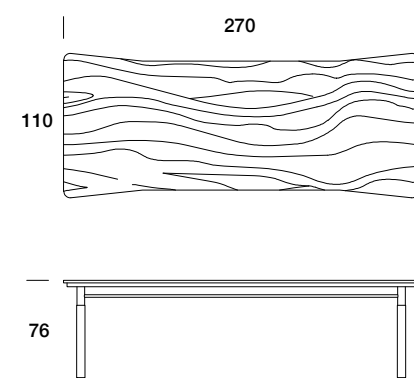
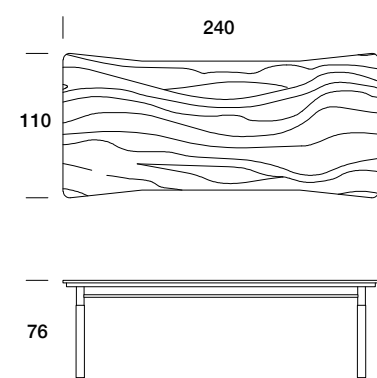

Tavolo con struttura in tubolare di acciaio con verniciatura galvanica resistente all'ossidazione e alla corrosione ed inserti decorativi in pelle.  
Piano in marmo e sottotop in legno con bordo laccato 100% Gloss.

Marble top, undertop made of wood with lacquered sides 100% Gloss. Legs and base made of stainless steel, legs upholstered with leather.

## Iris Little Armchair

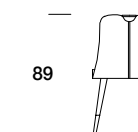
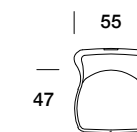
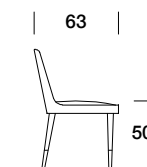

Sedia / poltroncina con struttura in legno e seduta imbottita. Schienale leggermente imbottito con inserto maniglia in acciaio ideale per facilitarne lo spostamento. Rivestimento in tessuto o pelle.  
Gambe interamente rivestite in pelle con puntali in acciaio inox.

Chair with wooden structure, seat and back featuring a light padding, upholstered with fabric or leather. Structure upholstered with leather featuring stainless steel decorations on the back. Legs fully upholstered with leather and featuring stainless steel ferrules.

## Rania Armchair

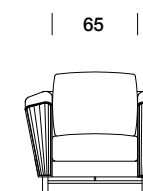
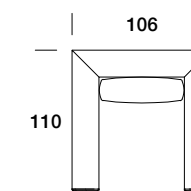
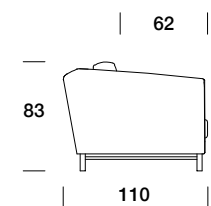

Poltrona dalla struttura a pozzetto con bracciolo degradante all'esterno caratterizzato dal frontale plissettato con lavorazione a "canaletta", realizzabile sia in pelle che in tessuto.  
Struttura in legno massello con base portante a vista in acciaio con verniciatura galvanica resistente all'ossidazione e alla corrosione.  
Cuscino seduta realizzato in poliuretano e inserti in piuma d'oca.  
Cuscino schienale con imbottitura in piuma d'oca.

Armchair with cockpit- solid wood structure, lightly padded and upholstered with fabric or leather. Armrests degrading to the front side; frontals of the armrests with wooden masks featuring grooves upholstered with fabric or leather. Steel base and legs.

## Rebel Sofa

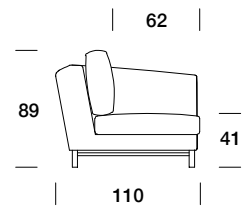

Sofa

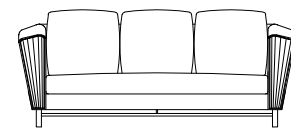

210

Sofa

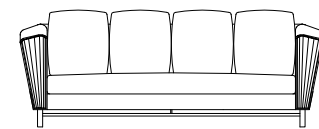

230

Sofa

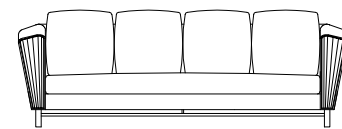

250

Terminal sofa SX

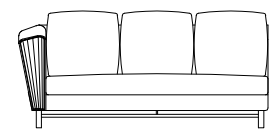

190

Terminal sofa DX

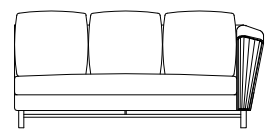

190

Terminal sofa SX

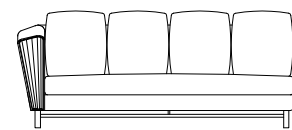

210

Terminal sofa DX

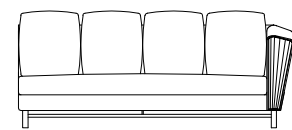

210

Terminal sofa SX

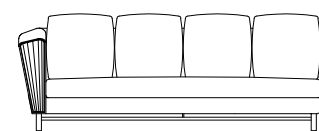

230

Terminal sofa DX

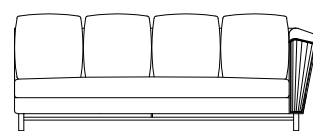

230

Chaise longue SX

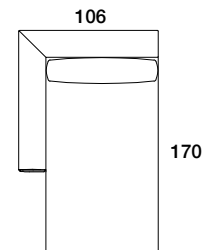

106

170

Chaise longue DX

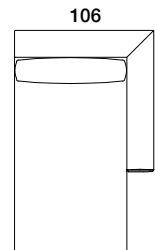

106

170

Divano dalla struttura a pozzetto con bracciolo degradante all'esterno, caratterizzato dal frontale plissettato con lavorazione a "canaletta", realizzabile con rivestimento sia in pelle che in tessuto.  
Struttura in legno massello con base portante a vista in acciaio con verniciatura galvanica resistente all'ossidazione e alla corrosione.  
Cuscino seduta unico realizzato in poliuretano espanso e inserti in piuma d'oca; cuscini schienale con imbottitura in piuma d'oca.

Sofa with solid wood structure, lightly padded and upholstered with fabric or leather. Cockpit structure with armrests degrading to the frontal side.  
Armrest's frontals with wooden masks featuring grooves, upholstered with fabric or leather. One-piece seat cushion made with high-density polyurethane foam and down feather. Free standing back cushions. Stainless steel base and legs.

## Talis Cofee Tables

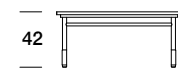
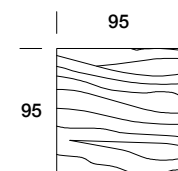
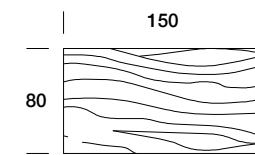
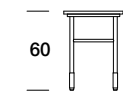
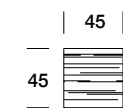

## Tobia Cofee Tables

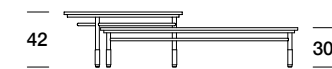
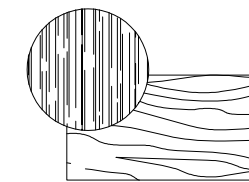
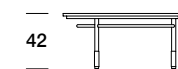
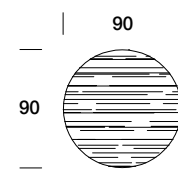
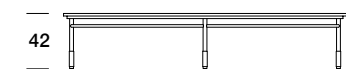
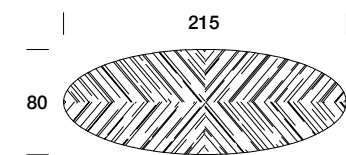
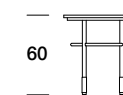
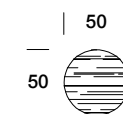

Serie di tavolini dai diversi formati e diverse altezze con struttura in tubolare di acciaio con verniciatura galvanica resistente alla corrosione e inserti decorativi in pelle.  
Piano in marmo e sottotop in legno con bordo laccato 100% Gloss.

Coffee tables with various sizes and heights. Volakas marble or wooden top Ebony Emara veneered 100% Gloss. Undertop made of wood lacquered 100% Gloss. Stainless steel legs and base, legs upholstered with leather

## Monolith Bed

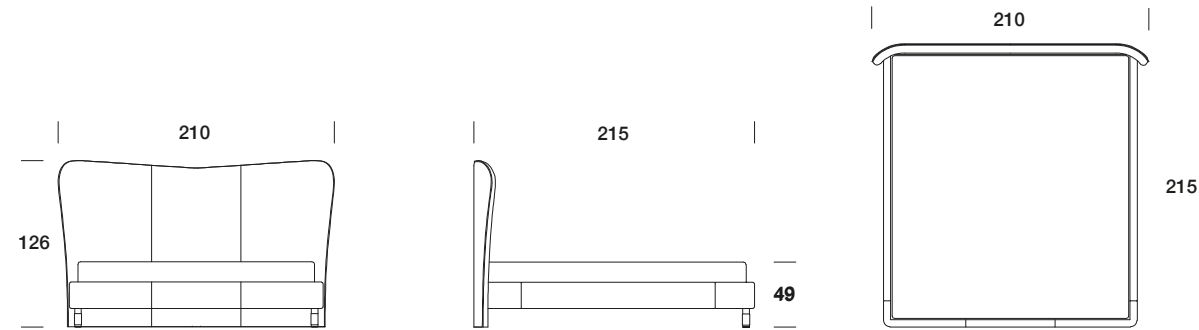

Letto con sommier realizzato in legno leggermente imbottito e rivestito in pelle.  
Testata imbottita dalle forme morbide, non spigolose grazie all'assenza di angoli acuti, con doppio rivestimento pelle e tessuto. Piedi in acciaio inox rivestiti in pelle.

Sommier upholstered with leather. Headboard featuring sinuous shape, without acute angles, with double upholstery fabric plus leather. Stainless steel legs with leather upholstery.

## Kikko Bedside Table

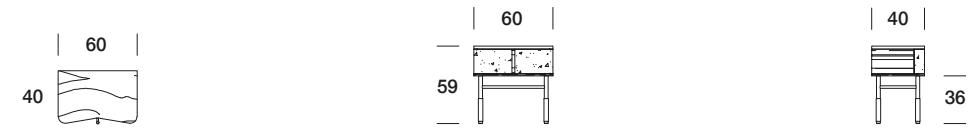

Comodino con interni, fianchi e schienale realizzati in legno listellare impiallacciato e verniciato lucido (100% Gloss).  
Struttura in tubolare di acciaio con verniciatura galvanica resistente all'ossidazione e alla corrosione. Inserti decorativi in pelle.  
Cassetto dalla forma non spigolosa - a richiamare le rotondità del disegno del top - con frontale rivestito in pelle e maniglia in acciaio inox con inserto in pelle; cabochon in pietra preziosa. Top in marmo.

Nightstand with wooden structure whose design matches the entire Rebel collection, featuring curved shapes without acute angles. Structure made of blockboard wood with Ebony Emara veneering 100% Gloss.  
Curved doors upholstered with fabric or leather, stainless steel handles upholstered with leather, cabochon on the top and on the bottom made of Tiger's Eye precious stone. Marble top. Stainless steel legs and base, legs upholstered with leather.

## Silea Chest of drawers

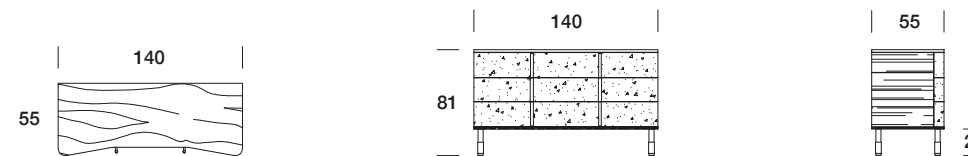

Mobile comò con interni, fianchi e schienale realizzati in legno listellare impiallacciato e verniciato lucido (100% Gloss).  
Piedi in tubolare di acciaio con verniciatura galvanica resistente all'ossidazione e alla corrosione; inserti decorativi in pelle.  
Cassetti dalla forma non spigolosa - a richiamare le rotondità del disegno del top - con frontale rivestito in pelle e maniglia in acciaio inox con inserto in pelle; cabochon in pietra preziosa. Top in marmo.

Chest of drawers with blockboard wooden structure Ebony Emara veneered, 100% Gloss. Drawer's frontals upholstered with leather. Stainless steel handles upholstered with leather and featuring precious stone cabochon on both the top and the bottom part. Marble top. Stainless steel legs with leather upholstery.

## Aliseo Mirror

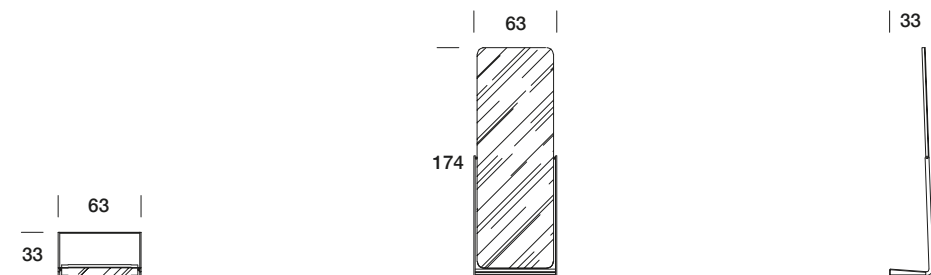

Specchiera regolabile in oscillazione realizzata con struttura in acciaio inox con verniciatura galvanica resistente alla corrosione e legno listellare impiallacciato e verniciato lucido (100% Gloss). Specchio trasparente da mm 8. Base di appoggio rivestita in pelle ed inserti nel telaio in pietra preziosa.

Mirror made with blockboard wood with 100% Gloss ebony emara veneering. 8 mm transparent mirror. Stainless steel frame. Lacquered base with Ebony Emara decorations on the the sides.

## Blasy Vanity

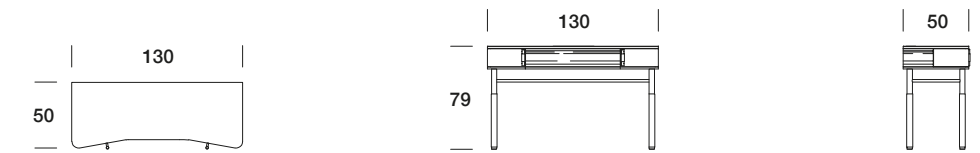

Mobile in listellare di legno impiallacciato e verniciato con finitura 100% Gloss.  
Struttura in tubolare di acciaio con verniciatura galvanica resistente all'ossidazione con inserti decorativi in pelle.  
Top ed antine curve laterali rivestiti in pelle. Cassetto centrale con frontale impiallacciato e verniciato con apertura push pull; interno rivestito in microfibra con colore in tinta. Cassetti laterali e cassetto centrale con vani interni porta oggetti, tutti rivestiti in microfibra con colore in tinta. Maniglie in acciaio inox parzialmente rivestite in pelle con cabochon in pietra preziosa.  
Optional la specchiera regolabile con struttura in acciaio verniciato e legno impiallacciato, con base di appoggio rivestita in pelle ed inserti nel telaio inox in pietra preziosa.

Vanity made of blockboard with 100% Gloss Ebony Emara veneering. Top and curved sides upholstered with leather to be chosen among our samples, in the picture stingray leather.  
Central drawer with Ebony Emara veneering and featuring push-pull opening, drawer's internal upholstered with microfiber with matching color. Side drawers and central drawer featuring storage compartments. Stainless steel handles with leather upholstery. Cabochon made of Tiger's Eye precious stone on the top and on the bottom of each handle.  
Optional: mirror fully veneered with adjustable inclination, stainless steel frame. Mirror's base upholstered with leather and featuring precious stone inserts on the steel frame. Legs and base made of stainless steel, legs upholstered with leather.

## Mirror for Blasy Vanity

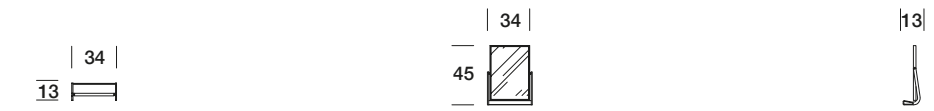

Specchiera regolabile con struttura in acciaio verniciato e legno impiallacciato, con base di appoggio rivestita in pelle ed inserti nel telaio in pietra preziosa.

Optional: mirror fully veneered with adjustable inclination, stainless steel frame. Mirror's base upholstered with leather and featuring precious stone inserts on the steel frame. Legs and base made of stainless steel, legs upholstered with leather.

## Lord Pouff

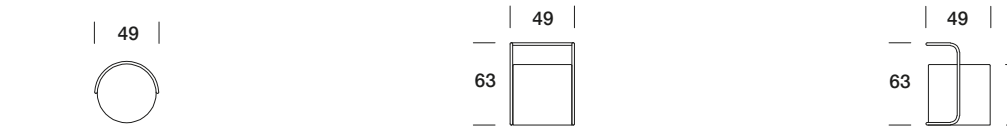

Pouf imbottito con struttura portante in legno massello e rivestimento in tessuto o pelle. Base e schienale in tubolare di metallo verniciato anti-touch

Solid wood structure, upholstered with fabric or leather. Base and back made of metal tubular anti-touch painted.

## Svevo Desk

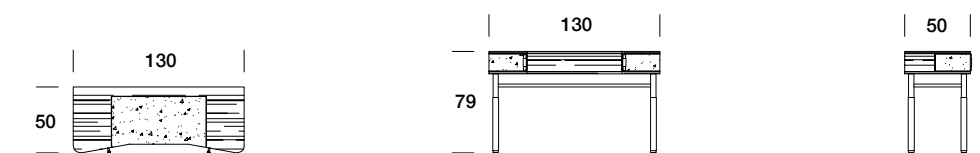

Mobile scrittoio con frontale cassetto centrale e fianchi in listellare di legno impiallacciato e verniciato lucido 100% Gloss.  
Struttura in tubolare di acciaio con verniciatura galvanica resistente all'ossidazione e con inserti decorativi in pelle.  
Parte centrale del top rivestito in pelle, come i cassetti laterali, rivestiti internamente in microfibra con colore in tinta.  
Maniglie in acciaio inox con finitura oro lucido ed inserto in pelle, con Cabochon in pietra preziosa.

Svevo Desk as per picture. Desk made of blockboard with 100% Gloss Ebony Emara veneering. Central top upholstered with leather, central drawer upholstered with matching color microfiber, featuring soft closure, drawer's frontal made of 100% Gloss Ebony Emara veneering. Frontal of the structure veneered with 100% Gloss Ebony Emara veneering. Handles made of stainless steel with shiny gold finish, upholstered with leather. Cabochon made of Tiger's Eye precious stone. Drawers on the sides upholstered with leather on the frontal doors, upholstered with microfiber matching color on the inside. Stainless steel legs with shiny gold finish upholstered leather.

AD / Styling: Beatrice Carollo

Photo: Studio Leon

Photolito: Colorediting

Rendering: Virtuald



FORMERIN ITALIA srl  
Via Emilia Romagna 2  
61020 Gallo (Pesaro) Italia  
tel. ++39 0722 52176  
fax ++39 0722 52640  
www.formerin.it  
e-mail: info@formerin.it

